

SCALE 1:10
 (EXAMPLE OF A SLIDING WINDOW, VERSION XO,
 SIZE 1000 X 1000 mm, VIEWED FROM OUTSIDE.)

4

5

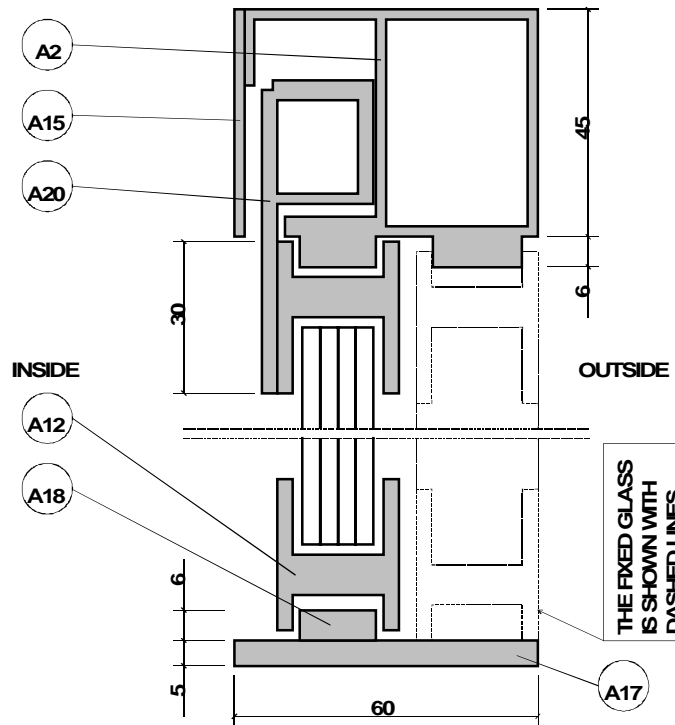

EXPLANATIONS

ALL MEASURES ARE IN MILLIMETRES.

NOTES

THE SLIDING WINDOW SHALL BE TYPE 6018, SVALSON AB, SWEDEN (+46 911 667 25).

CONSTRUCTION

MOTOR, TRANSMISSION AND AUTOMATIC LOCKING SHALL BE PLACED WITHIN THE FRAME.

LOCKING

THE SLIDING WINDOWS SHALL BE LOCKED AUTOMATICALLY IN CLOSED POSITION AND EACH 50 mm OF THE OPENING WIDTH.

FINISH

THE ALUMINIUM PROFILES SHALL BE SATIN ANODISED. (OR ANY OTHER FINISH, FOR INSTANCE COLOUR COATED OR ANODISED IN OTHER COLOURS.)

GLASS

16 mm LAMINATED GLASS CLASS B1. (OR ANY OTHER TYPE OF GLASS WITH A MAXIMUM THICKNESS OF 20 mm. FOR INSTANCE DOUBLE GLAZING 4-12-4.)

SEE DRAWING AUPROFIL-1-E AND -2-E FOR PROFILE DIMENSIONS

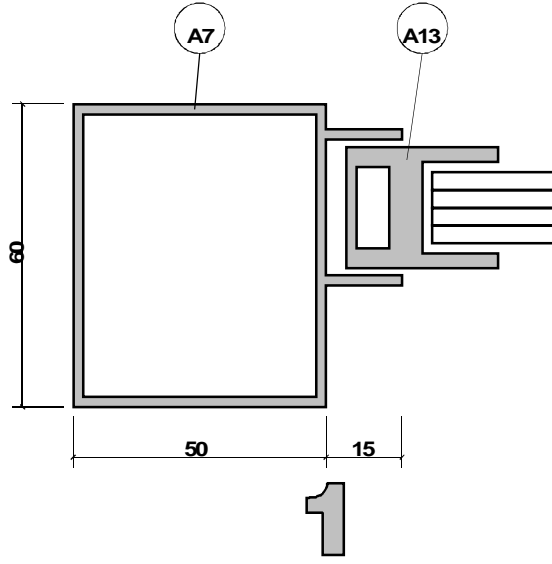

1

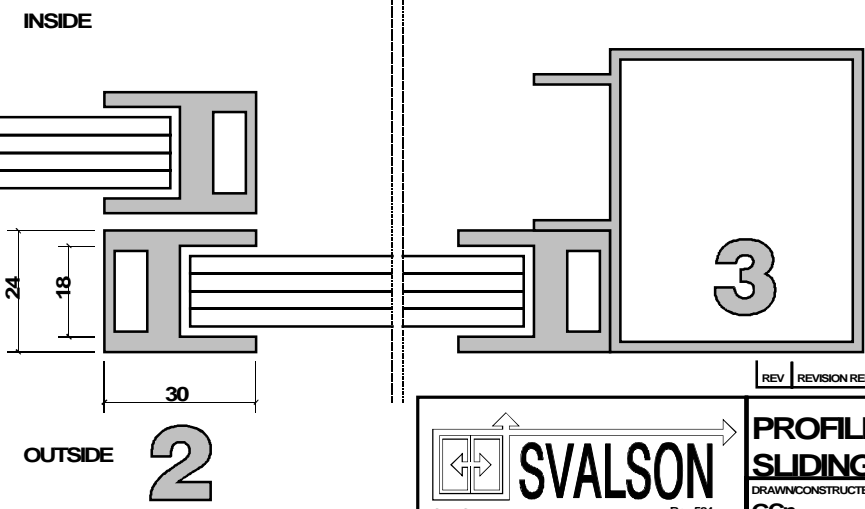

2

REV	REVISION REFERS TO	DATE	SIGN
-----	--------------------	------	------

		PROFILE DRAWINGS	
		SLIDING WINDOW TYPE 6018	
DRAWN/CONSTRUCTED BY G.Cn	SCALE 1:1	VIEW FROM OUTSIDE <input checked="" type="checkbox"/>	
DATE 1996-11-22	DRAWING NUMBER AU6018-E	VIEW FROM INSIDE <input type="checkbox"/>	
		REV	

SVALSON AB
 Phone +46 911 667 25
 Telefax +46 911 666 80

Box 584
 S-943 28 Ojebyn
 SWEDEN